

# EvilAmy Log Cabin

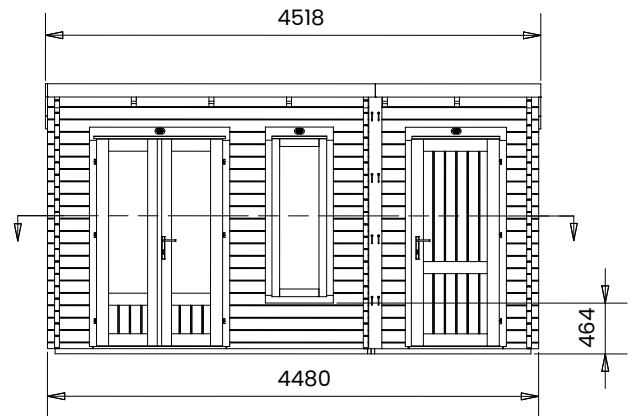
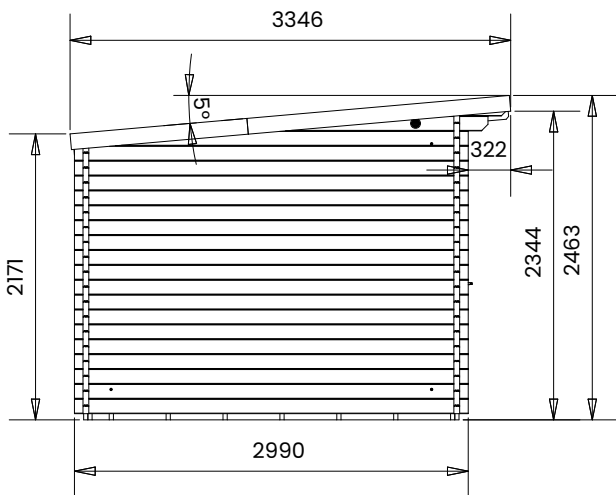
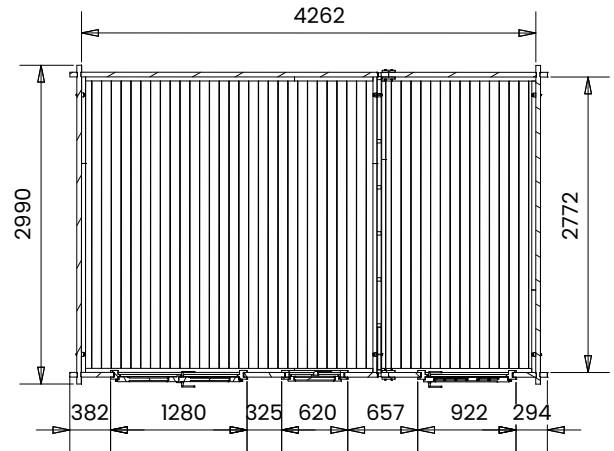

## Specification

- Overall External Dimensions: 4.52m x 3.35m (14' 9" x 10' 11")
- External Width: 4.48m (14' 8")
- External Depth: 2.99m (9' 9")
- Main Room Internal Width: 2.77m (9' 1")
- Main Room Internal Depth: 2.27m (7' 5")
- Main Room Internal Area (m<sup>2</sup>): 7.67
- Store Room Internal Width: 1.45m (4' 9")
- Store Room Internal Depth: 2.77m (9' 1")
- Store Room Internal Area (m<sup>2</sup>): 4.02
- Ridge Height: 2.46m (8' 0")
- Internal Eaves Height Front (to under the roof boards): 2.32m (7' 7")
- Internal Eaves Height Front (to under the roof purlins): 2.18m (7' 1")
- Internal Eaves Height Back (to under the roof boards): 2.07m (6' 9")
- Internal Eaves Height Back (to under the roof purlins): 1.93m (6' 3")

- Roof Overhang: 0.32m (1' 0")
- Roof Thickness: 19mm Tongue & Groove
- Roof Covering Options: None or Felt
- Building Style: Strong Interlocking Tongue & Groove Logs
- Walls: 100% Slow-Grown Spruce
- Wall U-Value (W/m<sup>2</sup>K): 1.93 W/m<sup>2</sup>K
- Floor Thickness: 19mm Tongue & Groove
- Door Locking System: Industry Leading 4 Point Lock - 2 Cams, Latch & Hook Bolt
- Approx. Assembly Time: \*This is an approximate time only, based on 2 people. Assembly time may vary depending on season/weather conditions, foundation type, ability of those constructing, etc