

# Addroom® Modular Garden Room

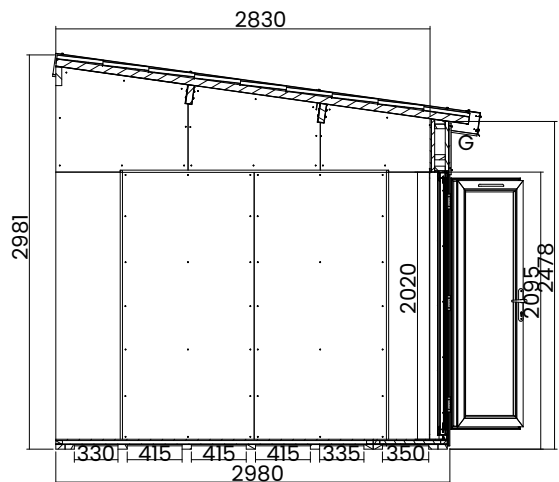
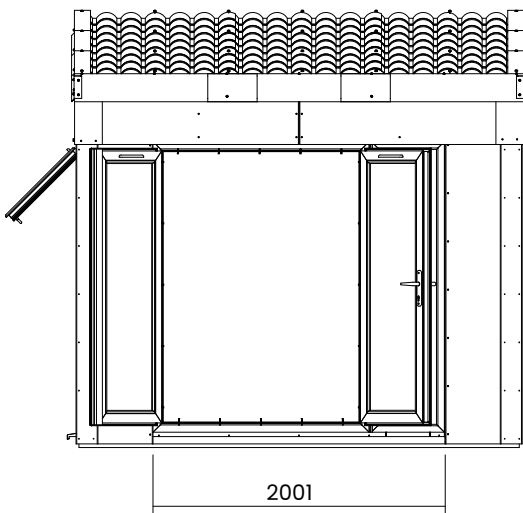
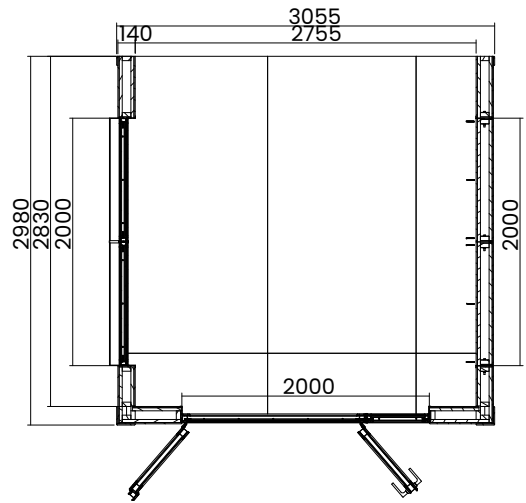

Image shows base product as an example and excludes any wall configurations.

## Specification

- **Please Note:** All sizes quoted are nominal
- **Overall External Dimensions:** 3.08m x 3.20m (10' 1" x 10' 5")
- **External Width:** 3.04m (9' 11")
- **External Depth:** 2.98m (9' 9.25")
- **Internal Width:** 2.76m (9' 0")
- **Internal Depth:** 2.83m (9' 3.5")
- **Internal Area (m<sup>2</sup>):** 7.81
- **Ridge Height:** 2.98m (9' 9")
- **Internal Eaves Height Front:** 2.40m (7' 10")
- **Internal Eaves Height Back:** 2.82m (9' 3")
- **Wall Thickness:** 140mm Insulated Panels (10mm WPC, 25mm PIR Insulation, 70mm Timber Frame, 25mm PIR Insulation, 10mm Fermacell)
- **Internal Finish:** Unpainted Fermacell Board
- **Roof Thickness:** 65mm
- **Roof Purlin Thickness:** 45mm

- **24mm Double Glazing:** Included As Standard
- **Floor Thickness:** 40mm Insulated Panels (5mm WPC, 25mm PIR Insulation and Timber Frame, 10mm MR P5)
- **Floor Bearers:** Pressure Treated
- **Door Material:** Reinforced 5 Chamber PVCu Profile
- **Door Opening Size:** 1.85m x 1.34m (6' 0" x 4' 4")
- **Windows Opening Size:** 0.61m x 0.89m (2' 0" x 2' 11")
- **Window Locking System:** Multi-Point Locking
- **Glazing Material:** 28mm Double Glazed
- **Gaskets:** On all Windows and Doors
- **Please Note:** 2 - 3 Days \*

\*This is an approximate time only, based on 2 people. Assembly time may vary depending on season/weather conditions, foundation type, ability of those constructing, etc