

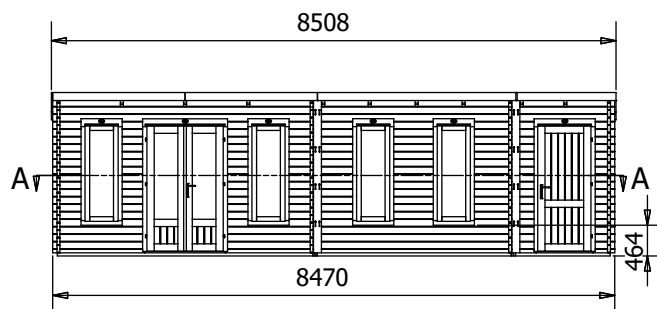

# EvilAmy Log Cabin

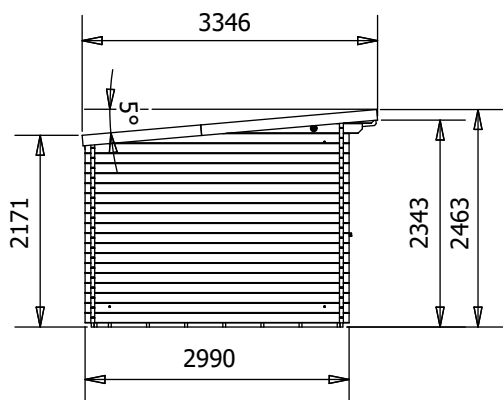
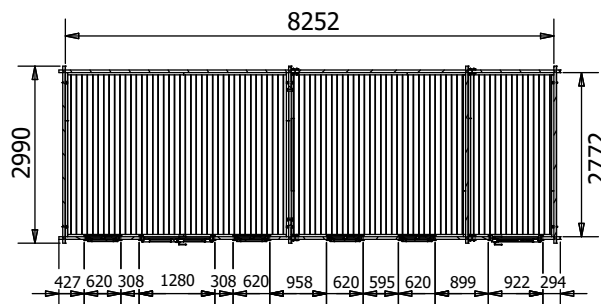

## Specification

- Overall External Dimensions: 8.51m x 3.35m (27' 11" x 10' 11")
- External Width: 8.47(27' 9")
- External Depth: 2.99m (9' 9")
- Main Room Internal Width: 6.76m (22' 2")
- Side Room Internal Width: 1.45m (4' 9")
- Internal Depth: 2.77m (9' 1")
- Main Room Internal Area (m<sup>2</sup>): 18.73m<sup>2</sup>
- Store Room Internal Area (m<sup>2</sup>): 4.02m<sup>2</sup>
- Ridge Height: 2.46m (8' 0")
- Internal Eaves Height Front: 2.32m (7' 7")
- Internal Eaves Height Back: 2.07m (6' 9")
- Roof & Floor Thickness: 19mm
- Floor Bearers: Pressure Treated

- Door Height (Walkthrough Height): 1.82m (5' 11")
  - Door Width (Walkthrough Width): 1.11m (3' 7")
  - Door Locking System: Industry Leading 6 Point Lock – 2 Cams, Latch & Hook Bolt, 2 Shootbolts
  - Window Locking System: Multi Point with Mushroom Headed Espagnolettes
  - Window Opening Size: 0.43m x 1.37m (1' 5" x 4' 5")
  - Glazing Options: 24mm Double Glazing as Standard!
  - Ventilation: 2 Plastic Vents Included
  - Approx. Assembly Time: 2 Days\*
- \*This is an approximate time only, based on 2 people. Assembly time may vary depending on season/weather conditions, foundation type, ability of those constructing, etc