

Deore Wooden Garage

Inc. Barn Doors

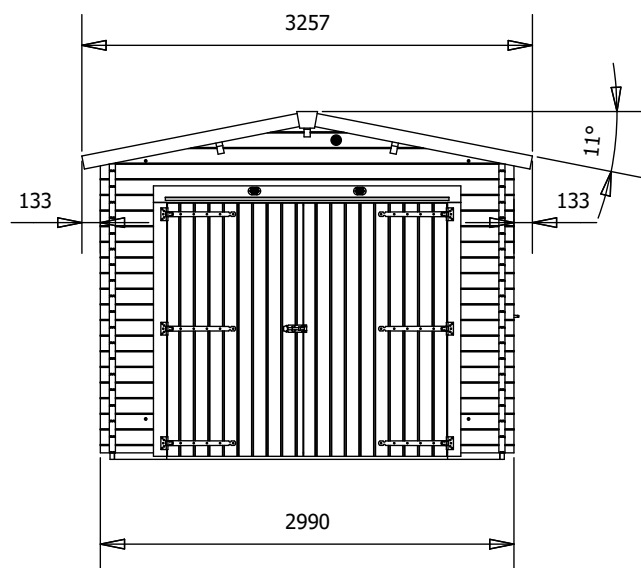
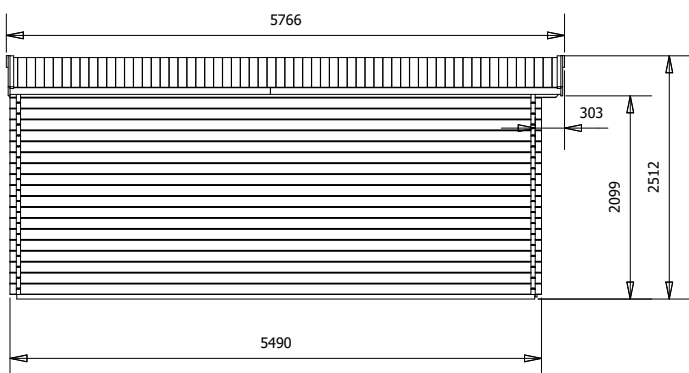
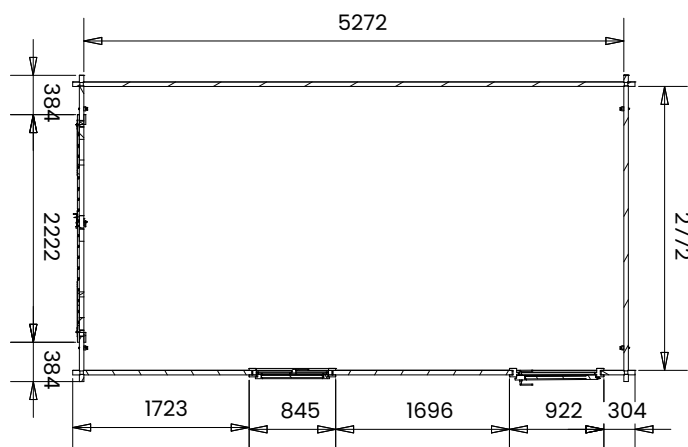

Specification

- **Please Note:** All sizes quoted are nominal
- **External Width:** 2.99m (9' 9")
- **External Depth:** 5.49m (18' 0")
- **Internal Width:** 2.77m (9' 1")
- **Internal Depth:** 5.27m (17' 3")
- **Internal Area (m²):** 14.60m²
- **Ridge Height:** 2.51m (8' 2")
- **Internal Eaves Height:** 2.20m (7' 2")
- **Roof Thickness:** 19mm Tongue & Groove
- **Roof Covering Options:** None, Felt or Shingles
- **Wall U-Value (W/m²k):** 2.59
- **Wall Thicknesses Available:** 45mm Tongue & Groove
- **Walls:** Spruce
- **Floor Bearers:** Pressure Treated
- **Side Door Style:** Single Door, Part Glazed
- **Side Door Locking System:** Industry Leading 4 Point Lock - 2 Cams, latch & Hook Bolt
- **Side Door Opening Size:** 0.64m x 1.79m (2' 1" x 5' 10")
- **Door Walkthrough Height:** 1.82m (5' 11")
- **Garage Door Opening Size:** 1.99m x 1.83m (6' 6" x 6' 0")
- **Window Locking System:** Multi Point with Mushroom Headed Espagnolettes
- **Window Opening Size:** 0.66m x 1.08m (2' 1" x 3' 6")
- **Glazing Material:** 4mm Toughened Glass
- **Glazing Options:** 24mm Double Glazing Included As Standard
- **Ventilation:** 2 Plastic Vents Included
- **Adjustable Storm Braces:** Included