

Overlord Modular Shed

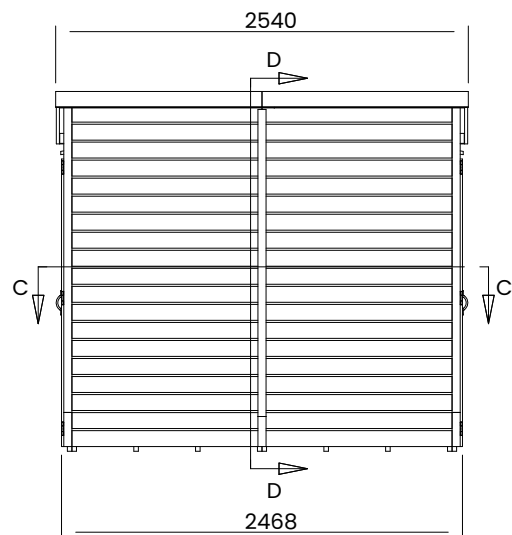
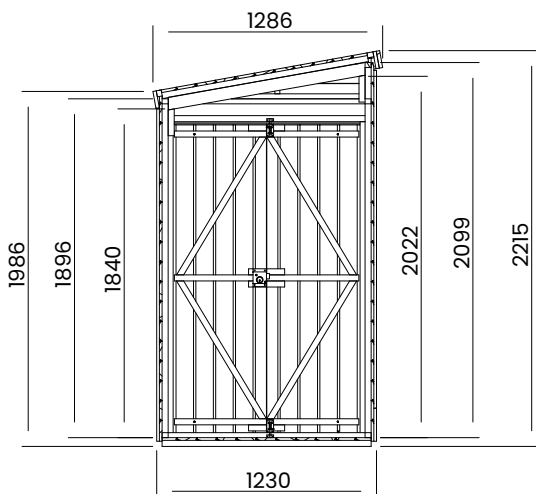
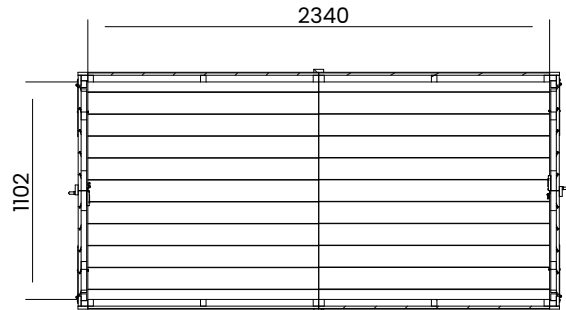

Specification

- Overall External Dimensions: 2.540m x 1.286m (8' 4" x 4' 2.75")
- External Width: 2.468m (8' 1.25")
- External Depth: 1.230m (4' 0.5")
- Internal Width: 2.340m (7' 8.25")
- Internal Depth: 1.102m (3' 7.5")
- Internal Area (m²): 2.579m²
- Ridge Height: 2.215m (7' 3.25")
- Internal Eaves Height: 2.099m (6' 10.75")
- Roof Thickness: 15mm Tongue & Groove
- Roof Covering Options: Roof Felt Included
- Roof Purlins: 35mm x 70mm

- Walls: 15mm Tongue & Groove
- Framing: 28mm x 34mm
- Floor Thickness: 15mm Tongue & Groove
- Windows: Without Windows
- Glazing Material: 4mm Toughened Glass
- Shed Door Locking System: Lock and 2x Shoot Bolts
- Shed Door Style: Double Doors
- Floor Bearers: Pressure Treated
- Timber: Pressure Treated Slow Grown Spruce
- Guarantee: 10 Year Guarantee on Timber against Rot and Insect Infestation