

# Dominator Garden Office

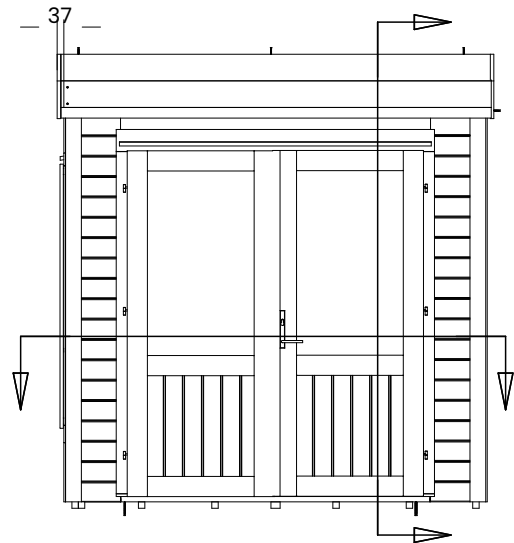
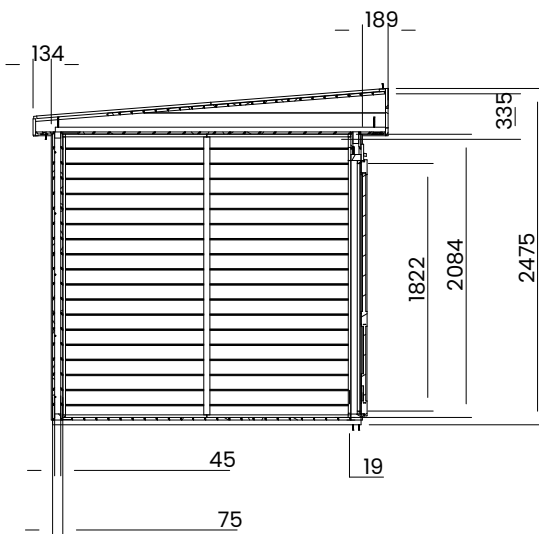
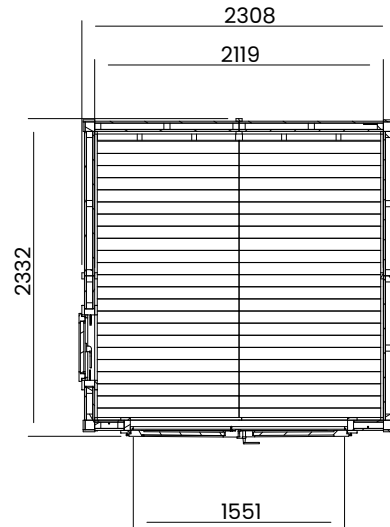

## Specification

- External Width: 2.30m (7' 6")
- External Depth: 2.33m (7' 7")
- Internal Width: 2.10m (6' 10")
- Internal Depth: 2.12m (6' 11")
- Internal Eaves Height: 2.09m (6' 10")
- Internal Area (m<sup>2</sup>): 4.45m<sup>2</sup>
- Roof: Insulated panel
- Roof Purlin Thickness: 140mm x 40mm Tapered
- Roof Thickness: 0.34m
- Roof U-Value (W/m<sup>2</sup>K): 0.49 W/m<sup>2</sup>K
- Roof Covering Options: Super Felt Included
- Ridge Height: 2.48m (8' 1")
- Overall Wall Thickness: 75mm
- External Timber Thickness: 15mm Shiplap Cladding
- Insulation Thickness: 25mm
- Framing: 45mm x 45mm
- Floor Thickness: 19mm

- Door Style: Double Glazed French doors
  - Door Locking System: Industry leading 6 Point Lock - 2 Cams, Latch & Hook Bolt, 2 Shootbolts
  - Door Walkthrough Height: 1.82m (5' 11")
  - Door Walkthrough Width: 1.55m (5' 1")
- Please Note: Pressure treatment is protecting against rot and infestation, it is not a water repellent. So we recommend a water repellent product to be used
- Approx. DIY Assembly Time: 1-2 Days\* \*This is an approximate time only, based on 2 people. Assembly time may vary depending on season/weather conditions, foundation type, ability of those constructing, etc