

Dominator Insulated Garden Office

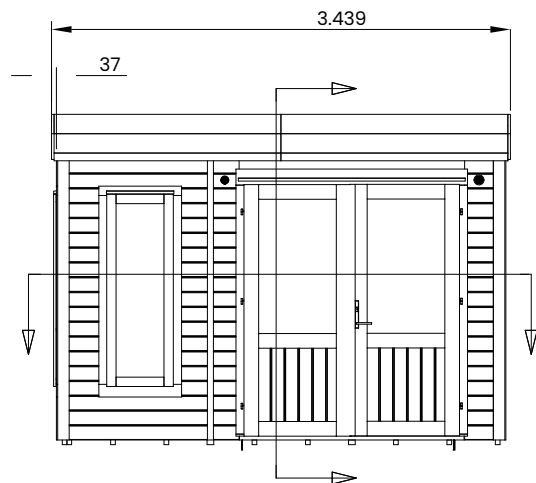
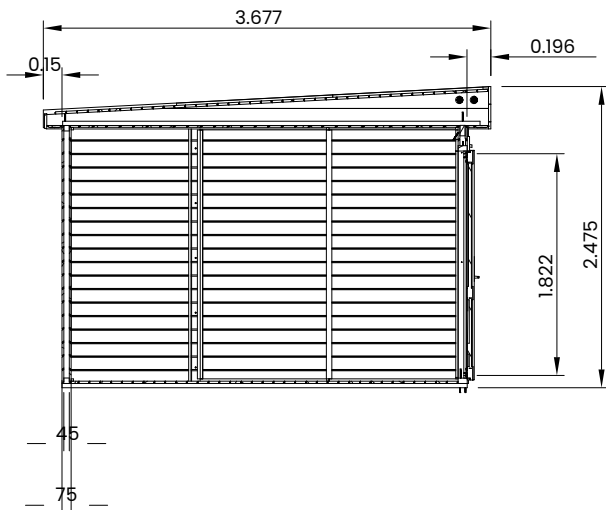
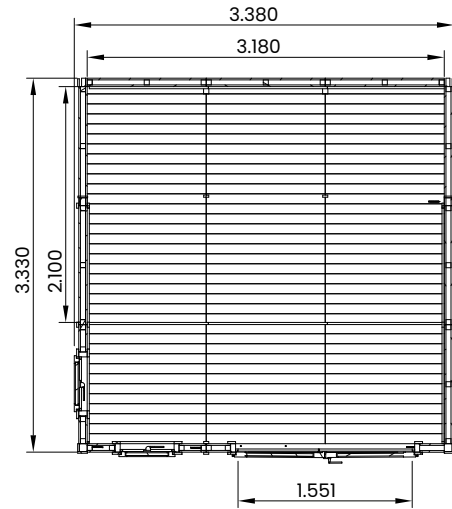

Specification

- **Please Note:** All sizes quoted are nominal
 - **Overall External Dimensions:** 3.44m x 3.68m (11' 3" x 12' 0")
 - **External Width:** 3.38m (11' 1")
 - **External Depth:** 3.33m (10' 11")
 - **Internal Width:** 3.18m (10' 5")
 - **Internal Depth:** 3.18m (10' 5")
 - **Internal Area (m²):** 10.11m²
 - **Ridge Height:** 2.48m (8' 1")
 - **Internal Eaves Height:** 2.09m (6' 10")
 - **Roof Thickness:** 0.34m
 - **Roof Covering:** Super Felt Included
 - **Overall Wall Thickness:** 75mm
 - **Floor Thickness:** 19mm
 - **Framing:** 45mm
 - **Door Walkthrough Height:** 1.82m (5' 11")
 - **Door Walkthrough Width:** 1.55m (5' 1")
 - **Door Locking System:** Industry Leading 6 Point Lock - 2 Cams, Latch & Hook Bolt, 2 Shootbolts
 - **Glazing Material:** Safer 4mm Toughened Glass
 - **Glazing Options:** 24mm Double Glazing Included as Standard!
 - **Gaskets:** On all Windows and Doors
 - **Please Note:** All fixings needed for assembly are supplied
 - **Please Note:** All wood is planed and pre-cut (with exception of trims), for quick and easy construction.
 - **Approximately DIY Assembly Time:** 1-2 Days*
- *This is an approximate time only, based on 2 people. Assembly time may vary depending on season/weather conditions, foundation type, ability of those constructing, etc